



# Black body Temperature Calibrator (CALfast 400BB) User's Guide



TEMPESENS INSTRUMENT (I) PVT. LTD UNIT II

A-190 ROAD #5, MIA UDAIPUR, 313003, INDIA

Phone: +91-294-3500600,

Fax: +91-294-3500631

Email: [tech@tempsens.com](mailto:tech@tempsens.com)

Web: [www.tempsens.com](http://www.tempsens.com)

## Legal Disclaimer

*The information contained in this document is the property of TEMPESENS.*

*TEMPESENS reserves the right to make changes to this document and to the product described herein without notice. Before installing and using the product, review the latest version of the applicable documentation, which are available from the Tempsens website at:*

*<http://www.tempsens.com>*

*© 2021 Tempsens Instrument Pvt. Ltd. All Rights Reserved.*

## Document Information

<b>NAME</b>	Black body Temperature Calibrator (CALfast 400BB) User Manual
<b>DOCUMENT VERSION</b>	1.0
<b>DOCUMENT CODE</b>	TS.CS.001
<b>PUBLISH DATE</b>	Wednesday, November 3, 2021

---

# Table of Contents

---

<b>Preface.....</b>	<b>5</b>
Safety Information.....	5
Electrical Safety.....	6
Health and Safety Instructions.....	7
Cautions and Preventions.....	8
Document Conventions.....	8
<b>Chapter 1.....</b>	<b>9</b>
<b>Introduction.....</b>	<b>9</b>
About CALfast 400BB.....	9
Basic Working Model of CALfast 400BB.....	10
Physical Measurements.....	11
Technical Specifications.....	13
<b>Chapter 2.....</b>	<b>14</b>
<b>Setting Up CALfast 400BB.....</b>	<b>14</b>
Installation.....	14
Optimal Environmental Conditions.....	14
Unpacking and Initial Inspection.....	15
Operating Instructions.....	16
Initial Testing.....	16
<b>Chapter 3.....</b>	<b>17</b>
<b>Optics.....</b>	<b>17</b>
Distance of pyrometer from object.....	19
Viewing Angles.....	19
<b>Chapter 4.....</b>	<b>20</b>
<b>Operating CALfast 400BB.....</b>	<b>20</b>
Turning On the Unit.....	20
Heating Up the Source.....	20
Operating Instructions.....	21
Cooling Down the Source.....	22

---

<b>Chapter 5 .....</b>	<b>23</b>
<b><i>Operating Unit Controller .....</i></b>	<b>23</b>
Front Panel Layout.....	23
The Temperature Controller.....	23
Altering the Set point.....	23
Monitoring the Controller Status.....	24
Temperature Units .....	24
<b>Chapter 6 .....</b>	<b>25</b>
<b><i>Digital Communication .....</i></b>	<b>25</b>
Digital Communications Wiring .....	25
Digital Communications Parameters.....	26
<b>Chapter 7 .....</b>	<b>27</b>
<b><i>Software Installation.....</i></b>	<b>27</b>
Installation .....	27
Parameters on Main Screen .....	27
<b>Chapter 8 .....</b>	<b>29</b>
<b><i>Service &amp; Maintenance .....</i></b>	<b>29</b>
Routine service.....	29
Replacing Controlling Sensor .....	29
Replacing Solid State Relay.....	29
<b>Chapter 9 .....</b>	<b>31</b>
<b><i>Troubleshooting CALfast 400BB .....</i></b>	<b>31</b>
CALfast 400BB unit does not turn on.....	31
The CALfast 400BB unit is not stable .....	31
The temperature of the Calibrator Unit does not rise.....	31
<b><i>Appendix A: Calibration Services.....</i></b>	<b>32</b>
In House Calibration Facility.....	32
On-site Calibration Facility.....	33
Fixed-point Calibration Facilities .....	33
<b><i>Appendix A: Warranty .....</i></b>	<b>35</b>
Limit of Liability.....	35
Caution in Using the Product .....	35

# Preface

Welcome to the Black body Temperature Calibrator (CALfast 400BB) user guide. This guide provides detailed information about all the product options and features, and explains how to use the product and configure basic settings to suit your requirements.

This user manual contains information about the product and its proper use and should be kept in a place where it will be easy to access. This user manual also provides safety precautions in using this product.

## Safety Information





This topic contains important information regarding safety. Ignoring safety precautions may cause serious personal injury or damage to the unit and/or its components. Use the equipment only as specified in this manual. Otherwise, the protection provided by the instrument may be impaired.

Refer to the safety information in the Electrical Safety and Health and Safety Instructions sections or wherever specified in this manual.

The following definitions apply to the terms “**Warning**” and “**Caution**”.

- “**Warning**” identifies conditions and actions that may pose hazards to the user.
- “**Caution**” identifies conditions and actions that may damage the instrument being used.

The following safety symbols may appear on CALfast 400BB unit:

SYMBOL	DESCRIPTION	SYMBOL	DESCRIPTION
	Risk of Danger. Important information. See Manual		Hazardous voltage. Risk of electric shock
	Caution, Hot Surface		Protective Earth Ground

## Electrical Safety

---

### **WARNING:**

- **This equipment must be correctly grounded before use. Make sure the ground conductor wire (colored green/yellow) in the main power cable is connected to a protective earth/ground. If the equipment is not properly grounded, the high voltage may flow through the equipment body (chassis). SEVERE INJURY OR DEATH may result if personnel fail to observe safety precautions.**
  - **Do not remove the panels from the equipment without proper safety measures to avoid internal main power supply voltage hazard.**
- 

To avoid possible electric shock or personal injury, follow these guidelines.

- ⌚ This equipment uses protective earth circuit to ensure that the conductive parts do not store electric charges or conduct electricity if insulation fails.
- Before connecting the equipment to the electricity supply, understand the parts of the calibrator with the help of operating manual.
- Use power cables only with appropriate voltage and power rating, and that are approved for usage in your country.
- Replace the main power cable if the insulation is damaged, or if the insulation shows signs of wear and tear.
- DO NOT put the product at the location where access to the main power is blocked.
- DO NOT use an extension cord or adapter plug.
- DO NOT use the product if it operates incorrectly.
- Make sure the power cord does not touch the hot parts of the product.

---

## Health and Safety Instructions

---

 **WARNING: BURN HAZARD - DO NOT touch the well access surface of the unit at high temperature**

---

To avoid possible health and safety concerns, follow these guidelines.

- Wear appropriate protective clothing before using the equipment.
- Operators of this equipment should be adequately trained in the handling of hot and cold items and liquids.
- Do not use the apparatus for jobs other than those for which it was designed, that is, the calibration of thermometers.
- Do not handle the apparatus when it is hot (or cold), without wearing the appropriate protective clothing and having the necessary training.
- Do not drill, modify or otherwise change the shape of the apparatus.
- Do not use the apparatus outside its recommended temperature range.
- After use, do not return the apparatus to its carrying case until the unit has cooled down.
- There are no user serviceable parts inside. When required, contact Tempsens agent for repair.
- Ensure all materials, especially flammable materials are kept away from the hot parts of the apparatus, to prevent fire risk.
- Do not use the product around explosive gas, vapor, or in damp or wet environments.
- Make sure that the space around the product meets minimum space requirements.
- DO NOT turn off the unit at temperatures higher than 100°C. This could create a hazardous situation. Select a set-point less than 100°C and allow the unit to cool before turning it off.
- The top sheet metal of the furnace may exhibit extreme temperatures for areas close to the well access.
- Materials used in this furnace may be irritating to skin, eyes, and respiratory tract. Consult the material manufacturer's Material Safety Data Sheet (MSDS) to learn about those materials before using.





## Cautions and Preventions

To avoid possible damage to the instrument, follow these guidelines:

- Before working inside the equipment, turn the power off and disconnect the power cord.
- DO NOT turn the unit upside down with the inserts in place; the inserts will fall out of the unit.
- Use of this instrument at HIGH TEMPERATURES for extended periods of time requires caution.
- Completely unattended high temperature operation is not recommended for safety reasons.
- DO NOT plug the unit into 230 V if the heater switches and fuse holder reads 115 V. This action will cause the fuses to blow and may damage the instrument.
- Components and heater lifetime can be shortened by continuous high temperature operation.
- DO NOT use fluids to clean out the well.
- Never introduce foreign material into the probe hole of the insert. Fluids and other materials can leak into the calibrator causing damage.
- DO NOT drop or force the probe stems into the well. This type of action can cause a shock to the sensor and affect the calibration.

## Document Conventions

The documentation uses the following conventions.

 <b>Note:</b>	Configuration notes
 <b>Tip:</b>	Recommendations or suggestions
 <b>Important:</b>	Information regarding required or default configuration settings and product limitations
 <b>WARNING:</b>	Critical actions and configuration options
 <b>WARNING:</b>	

## Chapter 1

# Introduction

---

## 1.1 About CALfast 400BB

The **CALfast 400BB** has been designed to provide stable and accurate temperature source for on-site and laboratory calibration of radiation thermometers by comparison method up to a temperature ranges 100°C.

The **CALfast 400BB** model has been designed in single part. This model provides an isothermal enclosure in which the non-contact pyrometers can be checked against the temperature of the calibration black body. For traceable calibration a master pyrometer should be used. The unit's features emissivity of 0.98 thus offering the closest approximation of a target surface that is a perfect emitter of infrared energy. This model is suitable for onsite and the laboratory use for stable temperature readings.

The **CALfast** models are part of wide range of portable calibrators designed and made by Tempsens.

*Contact Tempsens to learn more about other products by Tempsens.*



## 1.2 Basic Working Model of CALfast 400BB

The purpose of the CALfast 400BB is to provide an isothermal enclosure for calibration purpose. The black body contains a heater and a control sensor that are used by the temperature controller to sense the black body temperature. To obtain and maintain a required temperature the controller varies the power to the heater via solid-state relay.

The calibrator controller uses a precision N-type thermocouple as a controlling sensor and controls the well temperature with heater. The CALfast 400BB Black body calibrator was designed for portability, moderate cost and ease of operation. With proper use, the instrument should provide continued accurate calibration of temperature sensors and devices.

### Important:

Before using the equipment, read the safety guidelines and operating procedures of the calibrator as described in the **Preface** of this user manual.

The basic working model for CALfast 400BB is as follows:

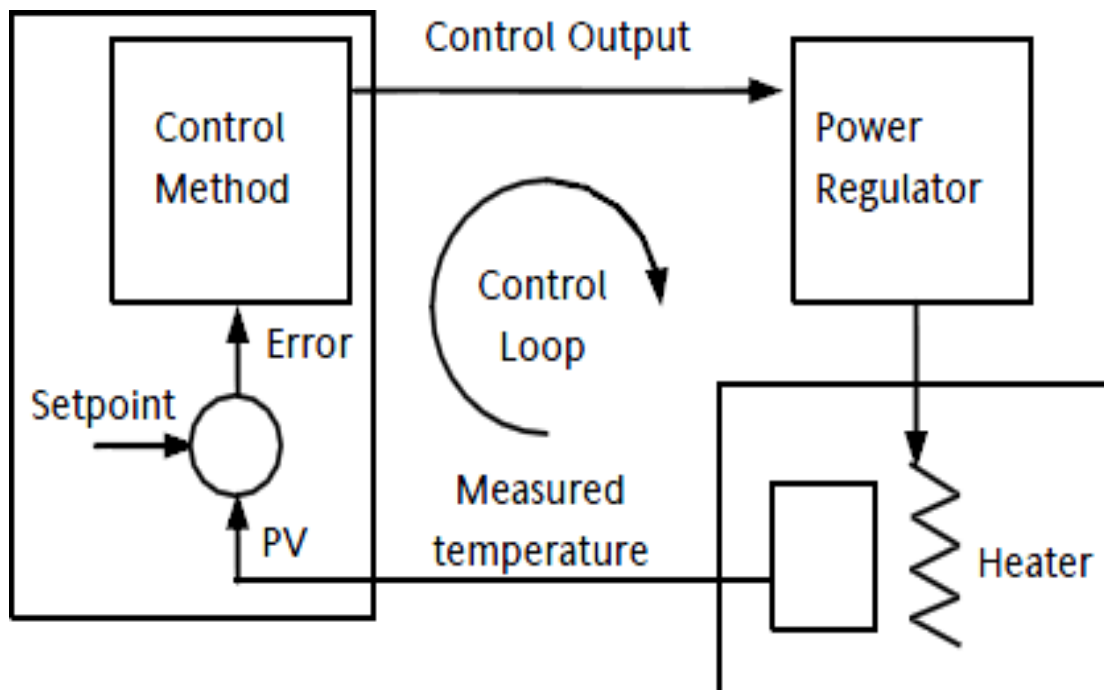

## 1.3 Physical Measurements

CALfast 400BB has the following physical measurements:

- Height: 120 mm
- Width: 200 mm
- Depth: 180 mm

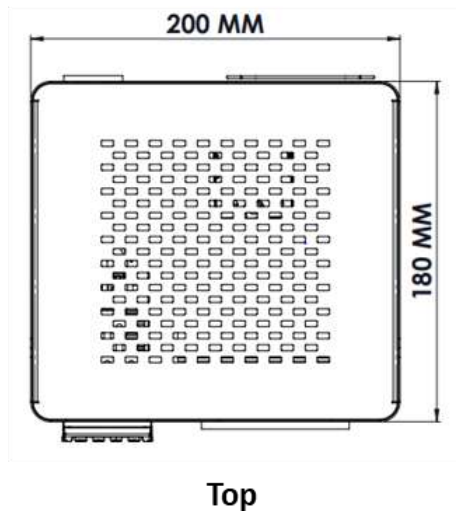
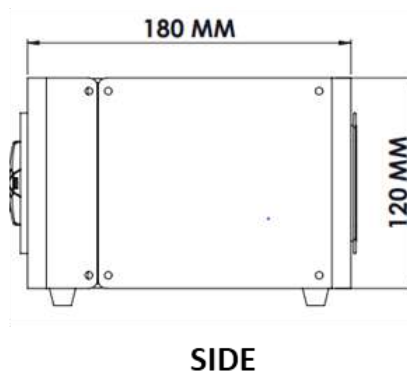
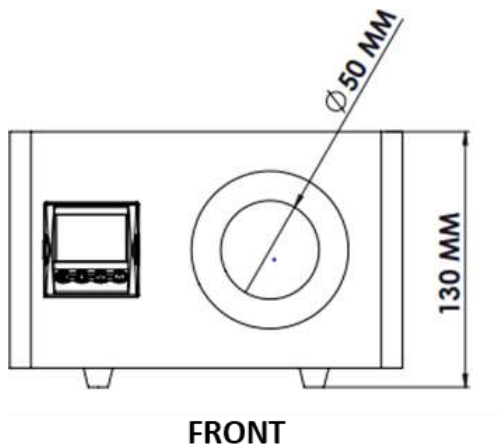

*This page is intentionally left blank*

## 1.4 Technical Specifications

CALfast 400BB has the following technical specifications:

PARAMETER	SPECIFICATION
Temperature range	40°C to 400°C
Stability	±0.1°C
BB cavity Aperture	50mm
Time to Reach Max. temperature	12 minutes
Resolution	0.1°C
Method of control	Digital self tuned PID controller
Power requirements	230VAC, 500W (50Hz)
BB cavity Emissivity	0.95 (± 0.02)
Calibration	Accredited calibration certificate provided
Environmental operating conditions	0°C to 40°C, 0% to 90% RH (non-condensing)
Operating temperature	20°C to 45°C
PC Interface	RS-232/USB
Size(HXWXD)	120(H)X200(W)X185(D) mm
Weight	2 kg

## Chapter 2

# Setting Up CALfast 400BB

---

## 2.1 Installation

Place the black body on a flat surface with at least 10 inches of free space around the instrument. Overhead clearance is required.

DO NOT Place this unit under a cabinet or structure. Plug the power cord into a grounded mains outlet located on the controlling unit rear panel. Observe that the nominal voltage corresponds to that indicated in the technical specifications in [Technical Specifications](#) in [Chapter 1](#) of this user's guide.

## 2.2 Optimal Environmental Conditions

Although the instrument has been designed for optimum durability and trouble-free operation, it must be handled with care. The instrument should not be operated in an excessively dusty or dirty environment. Refer to [0, Service & Maintenance](#) in this user's manual for routine service and cleaning recommendations.

The instrument operates safely under the following conditions:

- Temperature range: 5 - 50°C (41 - 122°F)
- Ambient relative humidity: 15 - 50%
- Pressure: 75kPa - 106kPa
- Main voltage supply within  $\pm 10\%$  of nominal voltage range
- Vibrations in the calibration environment should be minimized
- Altitude less than 2000 meters

## 2.3 Unpacking and Initial Inspection

CALfast 400BB is packed in custom-designed packaging to send out your unit. Unpack the furnace carefully. Inspect the unit after unpacking for any signs of damage, and confirm that your delivery is in accordance with the packing note. If you find any damage to the unit or an item is missing, notify Tempsens immediately.

The following accessories are included in the package:

- CALfast 400BB
- Power cable
- Manual
- Certificates
- Ceramic Wool



**CALfast 400BB**



**RS 232**



**Power cable**

---

## 2.4 Operating Instructions

1. Open the carrying case carefully and takeout the operating manual from the box and read carefully.
2. Take out the Black body Temperature Calibrator unit carefully and keep it at suitable place.
3. Connect the power cable to the rear power entry and the power plug to the main power outlet.
4. Turn the switch on, and observe the display on the controller. The display shows that the black body is ready for use.
5. Keep the switch in the ON position.
6. Keep the fan in ON position.
7. If the fan is running and temperature of the furnace is increasing/decreasing ,the black body is in healthy condition.



### Note:

- The unit must be correctly connected to the electricity supply.
- The unit must be correctly grounded. 
- The unit's ON/OFF switch is located on the power inlet. DO NOT switch OFF the unit when it is hot. Keep the unit running until cooled.

---

## 2.5 Initial Testing

This unit is fully tested before dispatching. However, verify its operation as follows:

1. After connecting the CALfast 400BB to the electricity supply, the temperature controller display should show the temperature of the chamber, and the last set-point value. The fan on the back should be heard running.
2. Change the set-point to 100°C and observe that the block temperature rises and settles to this value.
3. If the unit performs as expected, the unit can now be used for calibration.

If any problems or faults arise during the test, contact Tempsens immediately for help and advice.

## Chapter 3

# Optics

The pyrometer measures the temperature by receiving heat radiation from the object whose temperature has to be measured. This heat radiation is passed through the lens sensor and then converted to an electrical signal. The farther the measured object is from the pyrometer, the larger the area that will be measured by the pyrometer. Depending on customer need, the pyrometer is designed with fixed optics.

**Table 1: Some fixed optics focus is as below**

Manufactured working distances WD (mm)	Spot Sizes(mm)			
	A250 210°C - 1350°C (50:1)	A250 250°C - 1800°C (100:1)	A250 300°C - 2500°C 350°C - 3000°C (200:1)	A450 600°C - 2500°C (200:1)
350	7	3.5	1.75	1.75
700	10	5	2.5	2.5
500	14	7	3.5	3.5
<b>800</b>	16	8	4	4
<b>1000</b>	20	10	5	5
<b>1500</b>	30	15	7.5	7.5
<b>2000</b>	40	20	10	10
<b>2500</b>	50	25	12.5	12.5
<b>3000</b>	60	30	15	15
<b>5000</b>	100	50	25	25
<b>Aperture(A)</b>	<b>11</b>	<b>11</b>	<b>11 (300 - 2500°C)</b> <b>4 (350 - 3000°C)</b>	<b>12(600 - 2500°C)</b>

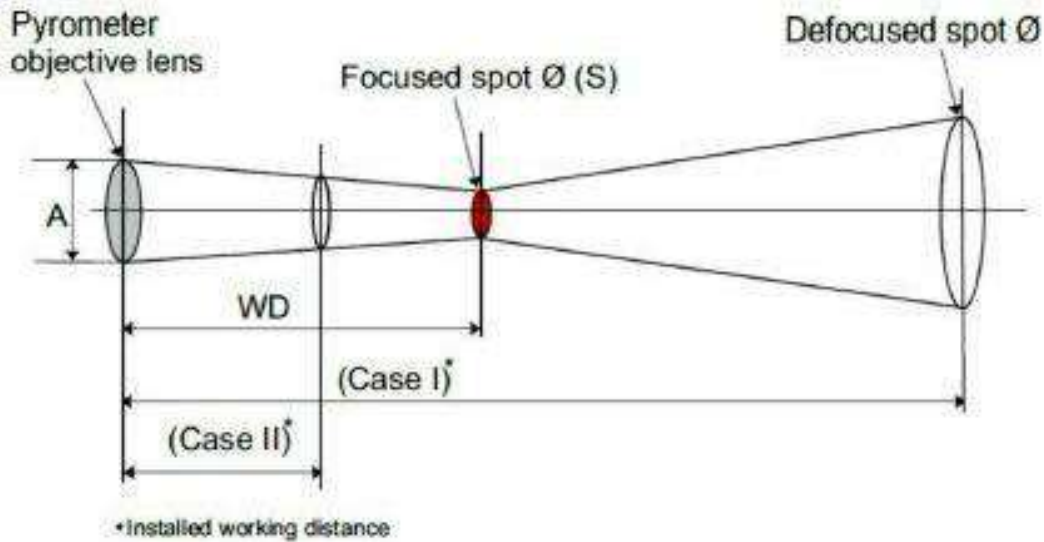

Manufactured working distance is mention on pyrometer.

If the pyrometer is not installed at manufactured working distance (WD) then spot size at actual installed distance should be calculated. For example, if factory made working distance is 500 mm & pyrometer is AST A250 (250 - 1800°C) then spot size is 5mm (as given in table). If user installed this pyrometer at 1000mm then spot size is not 10mm (as given in table), user should have to calculate as given below method.

**Case-I: If installed working distance is greater than manufactured working distance**

$$\text{Installed Spot size} = \frac{\text{Installed working distance (Case I)}}{WD} \times (S + A) - A$$

**Case-II: If installed working distance is smaller than manufactured working distance**

$$\text{Installed Spot size} = \frac{\text{Installed working distance (Case II)}}{WD} \times (S - A) + A$$

Where, S = manufactured spot size of pyrometer(mm), A = It shows the value of lens opening (aperture in mm)

### 3.1 Distance of pyrometer from object

The desired spot size on the target will determine the maximum measurement distance and the focal length of the optical module. To avoid wrong readings, the spot size of target must contain entire field view of the pyrometer. The pyrometer must be mounted so the entire field of view is the same or smaller than the desired target size. This is indicated in the below diagram.

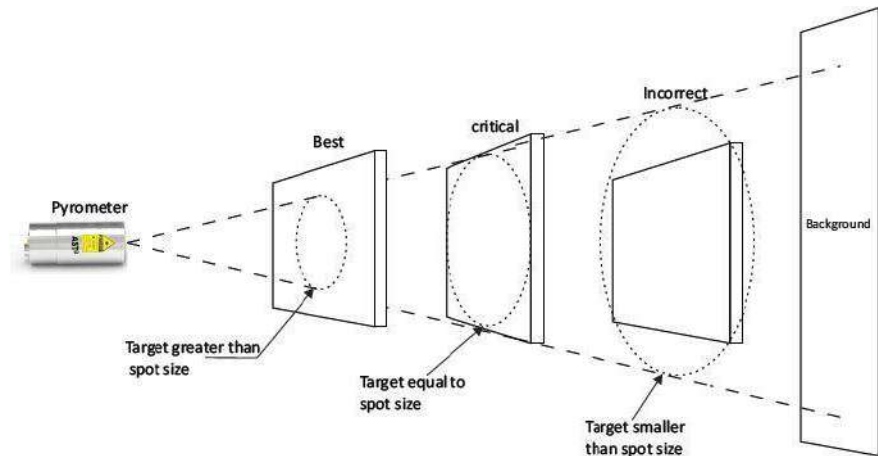

### 3.2 Viewing Angles

The pyrometer can be placed at any angle from the target object up to 30°. Indicated in the below diagram.

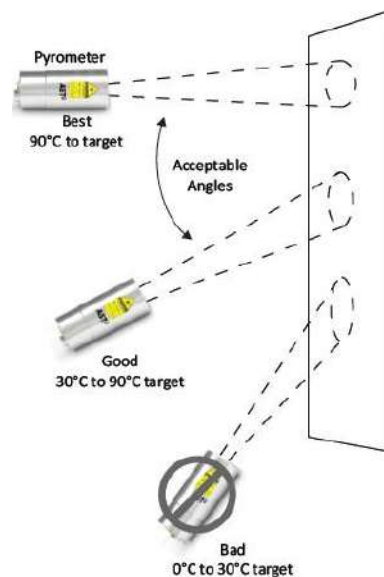

## Chapter 4

# Operating CALfast 400BB

---

## 4.1 Turning On the Unit

1. Before plugging the unit to main power outlet, ensure that the voltage, frequency and current from the main power outlet are within the recommended ranges (typically: 230 VAC $\pm$ 10, 50/60 Hz).
2. Turn the controller on using the switch located on the back, and set the temperature value in the controller. The Calibrator will turn on and begin to heat the previously programmed temperature set-point.



## 4.2 Heating Up the Source

Press “**UP**” or “**DOWN**” key of controller to change the set-point value. The controller switches the calibrator heater to ON or OFF to raise or lower the temperature. The displayed temperature will gradually change until it reaches the set-point temperature.

The Calibrator may require 15 to 20 minutes to reach the set-point depending on the span. The unit takes 15 to 20 minutes more to stabilize the body temperature within  $\pm 0.1^{\circ}\text{C}$  of the set-point.



Note:

- All other controller parameters are set to default, and are locked. It is recommended not to change these parameters.
-



**Important:**

- When the source is operated at any temperature above ambient temperature, the front face and plate become hot.
  - Always put the fan in "ON" condition and do not switch off the main power supply directly. Before tuning the unit off, set the controller to 0°C, and then wait until the temperature drops below 100°C.
- 

## 4.3 Operating Instructions

1. Connect the CALfast 400BB to a suitable power supply. ON the Mains switch located at back side with power entry.
  2. Set the desire temperature value in PID by using UP & Down key.
  3. Aim the reference (Master) standard infrared temperature sensor to the target area.
  4. PV (Present value) display in controller will gradually rise until it reaches the set point temperature. The controller takes some times to reach the set-point depending on the span. Furnace is stable when PV is equal to SV (Set Value).
  5. Master sensor takes some time to reach the set point temperature and stable at temperature near about controller set temperature.
  6. When temperature of the master and UUC (Unit under calibration) are stable record the readings of master sensor.
  7. Compare the UUC reading with the master's reading & find out the error by comparison method.
  8. Reset the controller and / or repeat the calibration for another calibration point or for another sensor.
  9. When the calibration is complete, reset the controller to 20°C & wait until the unit has cooled to below 50°C, before moving the CALfast 400BB to new location the CALfast 400BB must be cooled below 50°C before it can be put back into its carrying case.
- 



**Note:**

Always use a reference IR thermometer for comparison calibration method.

---

## 4.4 Cooling Down the Source

- Ensure that the temperature of Black Body has cooled sufficiently.
- If you require Black Body to cool quickly, set the temperature to the room temperature (ambient temperature).
- Always cool the heated instrument to ambient temperature before disconnecting it from the mains, switching it OFF, or removing the temperature sensor or test item.
- Always keep the heated instrument supervised and under observation until it cools down sufficiently.

## Chapter 5

# Operating Unit Controller

## 5.1 Front Panel Layout

The following image shows the front panel of **CALfast 400BB**.

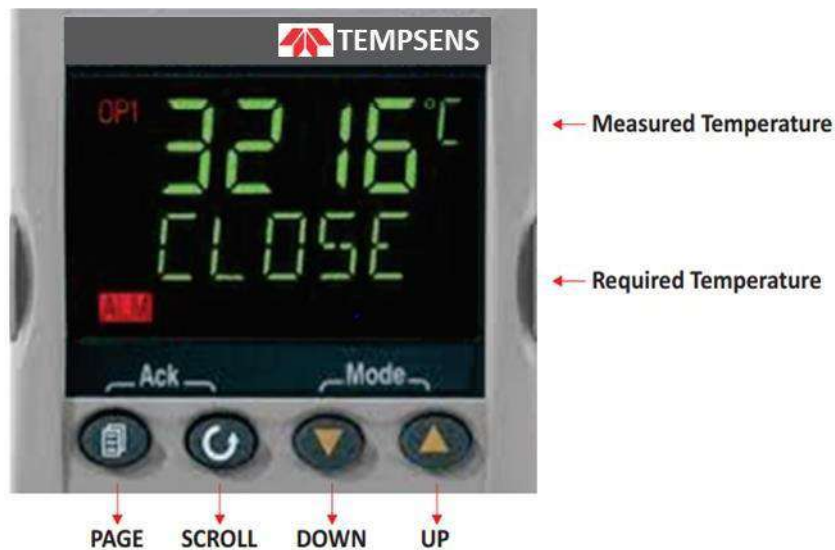

## 5.2 The Temperature Controller

The controller has a dual display, the upper display indicates the measured temperature, and the lower display indicates the desired temperature or set point.

## 5.3 Altering the Set point

To change the set point of the controller simply use the UP and DOWN keys to raise and lower the set point to the required value. The lower display changes to indicate the new set point.

## 5.4 Monitoring the Controller Status

A row of beacons indicates the controller's status as follows:

- OP1: Heat Output
- OP2: Cool Output (only for models which operate below 0°C)
- REM: This beacon indicates activity on computer interface

## 5.5 Temperature Units

Press the **Scroll** key to show the controller units in °C or °F.

## Chapter 6

# Digital Communication

Digital Communication allows the controller to communicate with a PC or a networked computer system through RS-232 (or EIA232) protocol. RS-232 (or EIA232) is a standard communication protocol for linking computer and its peripheral devices to allow serial data exchange. RS-232 communication is not available if Remote Set point is fitted. The cable screen should be grounded at one point only to prevent earth loops.

## 6.1 Digital Communications Wiring

To use EIA232 (or RS-232), the PC will be equipped with an EIA232 port, usually referred to as COM 1. To construct a cable for EIA232 operation use a three core screened cable. The terminals used for EIA232 digital communications are listed in the table below. Some PC's use a 25-way connector although the 9 way is more common.

STANDARD CABLE COLOR	PC SOCKET PIN No.		PC FUNCTION*	INSTRUMENT TERMINAL	INSTRUMENT FUNCTION
	9 WAY	25 WAY			
White	2	3	Receive (RX)	HF	Transmit (TX)
Black	3	2	Transmit (TX)	HE	Receive (RX)
Red	5	7	Common	HD	Common
Link Together	1	6	Received line signal detect Data terminal ready Data set ready		
	4	8			
	6	11			
Link Together	7	4	Request to send Clear to send		
	8	5			
Screen		1	Ground		

\* These are the functions that are normally assigned to socket pins. Check your PC manual to confirm.

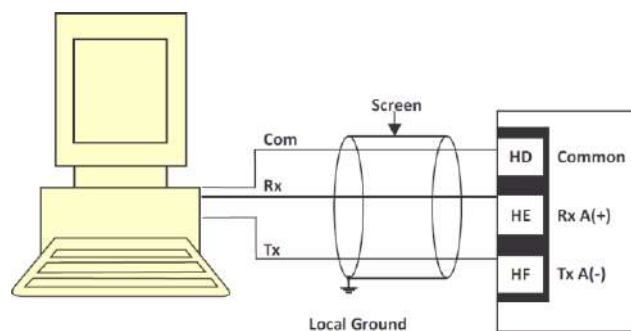

## 6.2 Digital Communications Parameters

The following table shows the available parameters.

Digital Communication List (comms)						
Name	Scrolling Display	Parameter Description	Value		Default	Access Level
ID	MODULE IDENTITY	Communication Identity	<i>nonE</i>	No module fitted	As order code	Conf L3 R/O
			<i>R232</i>	RS232 Modbus interface		
			<i>R485</i>	EIA485 Modbus interface		
			<i>r422</i>	EIA422 Modbus 3216 only		
			<i>Dc,P</i>	Remote set-point input. If fitted this ID replaces the above and no further parameters are shown		
Addr	COMMUNICATION ADDRESS	Communication address of the instrument	1 to 254		1	L3
BAUD	COMMUNICATION BAUD RATE	Communication Baud Rate	<i>1200</i>	1200	<i>9600</i>	
			<i>2400</i>	2400		
			<i>4800</i>	4800		
			<i>9600</i>	9600		
			<i>19.20</i>	19.20		
PRTY	COMMUNICATION PARITY	Communication Parity	<i>nonE</i>	No Parity	<i>nonE</i>	
			<i>EvEn</i>	Even Parity		
			<i>Odd</i>	Odd Parity		
DELAY	RX/TX DELAY TIME	To insert a delay between receiver (Rx) and transmitter (Tx) to ensure that drivers have sufficient time to switch over.	<i>Off</i>	No Delay		Conf L3 R/O
			<i>On</i>	Fixed Delay Applied		
RE Tran	COMMS RETRANS MISSION	Master Comms Broadcast parameter see section 15.2.1	<i>nonE</i>	None	<i>nonE</i>	
			<i>WSP</i>	Working setpoint		
			<i>pU</i>	Process variable		
			<i>OP</i>	Output Demand		
			<i>Err</i>	Error		
REGAD	COMMS RETRANS MISSION ADDRESS	Parameter added in slave address to which the master communication value will be written	0 to 9999			

## Chapter 7

# Software Installation

The provided Tempsens software offers possibilities to connect furnace temperature bath and change set point, maximum time span, view real time graph and evaluate measuring data.

## 7.1 Installation

Install the calibration software using the installation guide file on Pen drive. After installing the software, start the application. **CalSoft Tempsens Instruments** screen appears, as shown in screen Figure 1.

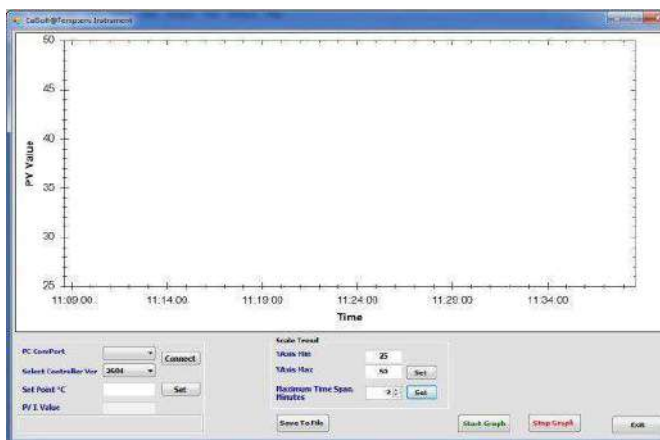

Figure 1 - Main screen



Figure 2 - PC ComPort



Figure 3 - Controller Version

## 7.2 Parameters on Main Screen

Communication between the furnace and the software is implemented via RS-232 cable connected between the furnace and the PC serial port. This enables the acquisition and recording of data, as well as the transfer of commands from the software application to the Tempsens furnace.

To communicate between the furnace and software application, select correct **COM port** (as shown in *Figure 2*) and Controller Version (**3216**) (as shown in *Figure 3*), and then click **Connect**.

To set the temperature of furnace as per your requirement, type the required temperature in **Set Point (°C)** field, and click **Set**.

PVI Value displays the current present value of furnace temperature.

The **Scale Trend** section enables you to configure **Y-Axis Min** (minimum value: **0**), **Y-Axis Max** (maximum value: **1500**), **Maximum Time Span** of data logging up to 120 minutes, and then click the **Start Graph** button. After completing the task, click **Save To File** to save settings to file. See *Figure 4*.



Figure 4 - Scale Trend Window

File will be stored in **.xls** format to save previous record. See *Figure 5*.

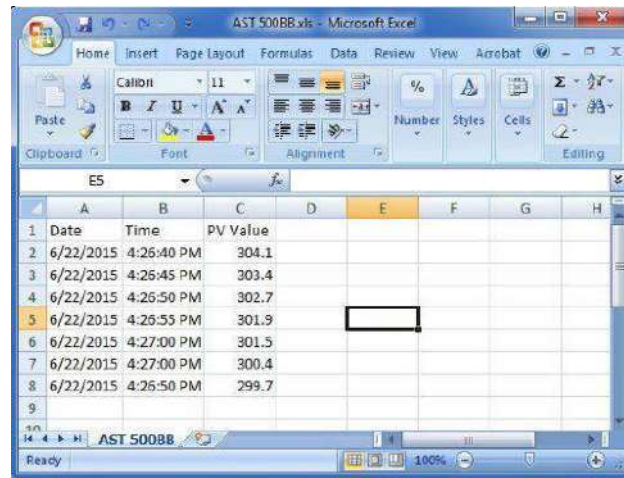

Figure 5 - Record in .xls Format

---

## Chapter 8

# Service & Maintenance

---

## 8.1 Routine service

Turn the electricity supply off before attempting any cleaning operation. The only moving part in this unit is fan, which is sealed for life.

Depending on the environment in which **CALfast 400BB** is used, periodic cleaning is recommended. Cleaning may be accomplished by the use of a small dry paint brush. The instrument should be periodically checked to ensure it is in good order both mechanically and electrically.

## 8.2 Replacing Controlling Sensor

Use the following steps to replace the controlling thermocouple sensor in the Calibrator Unit:

1. Disconnect the Calibrator Unit is from electrical supply.
2. Remove the cover of the Calibrator Unit.
3. Disconnect the thermocouple from the connector block.
4. Remove the thermocouple from the heating chamber present inside by unscrewing the fitting.
5. Insert and fit the new thermocouple into the heating chamber.
6. Reconnect the new thermocouple to the connector block.
7. Place the cover back on the Calibrator Unit.
8. Reconnect the furnace to the electrical supply.

## 8.3 Replacing Solid State Relay

Use the following steps to replace the sod state relay in the Calibrator Unit:

1. Disconnect the Calibrator Unit from the electrical supply.
  2. Remove the cover of the furnace.
  3. Locate the solid state relay.
  4. Note down the wire positions and then disconnect the wires.
  5. Remove the faulty relay and replace it with a new one.
  6. Tighten the fixing screws.
  7. Refit the wires back in position as you noted in step 4 of this procedure.
  8. Place the cover back on the Calibrator Unit.Reconnect the furnace to the electrical supply.
-



## Chapter 9

# Troubleshooting CALfast 400BB

---

## 9.1 CALfast 400BB unit does not turn on

If the CALfast 400BB unit does not turn on or operate as usual, check if the fuse is broken, and replace the fuse if necessary. If the fuse breaks repeatedly, contact Tempsens for technical support.

## 9.2 The CALfast 400BB unit is not stable

If the CALfast 400BB is not stable or the temperature varies too often, the control parameters might have been modified. If this happens, contact Tempsens for technical support.

## 9.3 The temperature of the Calibrator Unit does not rise

If the temperature of the Calibrator Unit does not rise, ensure the following:

1. The power cord is tightly fitted at the power entry location on the Calibrator Unit.
2. The power switch is turned ON.

If the temperature of the Calibrator Unit still does not rise even after you have inspecting and fitting the power cord and power switch, the reason can be one of the following:

- The heating element is not firmly closed. If the heating element is open, close it properly.
- The thermocouple is not firmly closed. If the thermocouple is open, close it properly.
- The Controller Unit may be not display correct reading.
- The SSR is damaged.

If the Calibrator Unit does not function properly, contact Tempsens immediately for technical support.

## Appendix A: Calibration Services

Tempsens Calibration Center is an independent unit of Tempsens instruments (I) Pvt. Ltd, having laboratories at Udaipur, Vadodara & Bangalore. It is accredited for wide range of temperature calibration services. It is the only private sector Laboratory in the country with accredited Fixed Point Temperature Calibration Facilities. The lab has highly stable calibration furnaces, measuring instruments and accurate master sensors traceable to National and International Standards. The calibration center functions as per ISO 17025 / NABL standards. Calibration of contact type sensors can be made in temperature range of -196°C to 1600°C and Calibration of non-contact type sensors can be made in temperature range 0°C to 2900°C. Further the laboratory is accredited for onsite temperature calibration.

The lab offers both at Lab & On-Site Calibration of Furnace/Bath from -80°C to 1600°C and Black Body Calibration from 50°C to 1700°C.

Furnace/Chamber Calibration (TUS) with multiple sensors from -80°C to 1200°C is also in the scope of the lab.

### In House Calibration Facility

QUALITY MEASURED / INSTRUMENTS	TEMPERATURE RANGE	CALIBRATION & MEASUREMENT CAPABILITY
Contact Type RTD, Thermocouples Thermometers	-196°C	0.05°C
	-80 to -38°C	0.03°C
	-38°C to 0°C	0.03°C
	>0°C to 140°C	0.04°C
	>140°C to 250°C	0.04°C
	>250°C to 650°C	0.12°C
	>650°C to 1200°C	1.30°C
	>1200°C to 1600°C	2.60°C
Non-Contact Type Pyrometer	0°C to 250°C	1.5°C
	>250°C to 500°C	2.4°C
	>500°C to 1500°C	2.5°C
	>1500°C to 1700°C	3.2°C
	>1700°C to 2900°C	4.0°C

### On-site Calibration Facility

QUALITY MEASURED / INSTRUMENTS	TEMPERATURE RANGE	CALIBRATION & MEASUREMENT CAPABILITY
Contact Type RTD, Thermocouples Thermometers	-25°C to 0°C	0.07°C
	>0°C to 140°C	0.04°C
	>140°C to 250°C	0.09°C
	>250°C to 650°C	0.12°C
	>650°C to 1200°C	1.30°C
Non-Contact Type Pyrometer	0°C to 250°C	1.50°C
	>250°C to 500°C	2.40°C
	>500°C to 1200°C	2.5°C
Multipoint Position Calibration of Chamber, Oven, Furnaces (Thermal Mapping(TUS))	-80°C to 200°C	2.8°C
	>200°C to 1200°C	4.1°C

### Fixed-point Calibration Facilities

QUALITY MEASURED / INSTRUMENTS	TEMPERATURE RANGE	CALIBRATION & MEASUREMENT CAPABILITY
Calibration of SPRT/PRTS/thermocouple and so on.	Triple Point of Water (0.01°C)	0.0038°C
	Melting Point of Gallium (29.7646°C)	0.0065°C
	Freezing Point of Tin (231.928°C)	0.0065°C
	Freezing Point of Zinc (419.527°C)	0.0071°C
	Freezing Point of Aluminum (660.323°C)	0.0075°C
Calibration of Thermocouple at Secondary Fixed Point	Melting Point of Gold (1064.18 °C)	0.72°C
	>1500°C to 1700°C	2.5°C
	>1700°C to 2900°C	3.2°C
	Melting Point of Palladium(1554.8	4.0°C
		0.83°C



---

## Appendix A: Warranty

---

This instrument has been manufactured to exacting standards and is warranted for twelve months against electrical breakdown or mechanical failure caused through defective material or workmanship, provided the failure is not the result of misuse. In the event of failure covered by this warranty, the instrument must be returned, carriage paid, to the supplier for examination and will be replaced or repaired at our option.

FRAGILE CERAMIC AND/OR GLASS PARTS ARE NOT COVERED BY THIS GUARANTEE

INTERFERENCE WITH OR FAILURE TO PROPERLY MAINTAIN THIS INSTRUMENT MAY INVALIDATE THIS GUARANTEE

### Limit of Liability

TEMPSSENS is not liable for any damages that arise from the use of any examples or processes mentioned in these Specifications are subject to change without notice.

### Caution in Using the Product

TEMPSSENS PRODUCTS ARE INTENDED FOR USE BY TECHNICALLY TRAINED AND COMPETENT PERSONNEL FAMILIAR WITH GOOD MEASUREMENT PRACTICES.

IT IS EXPECTED THAT PERSONNEL USING THIS EQUIPMENT WILL BE COMPETENT WITH THE MANAGEMENT OF APPARATUS WHICH MAY BE POWERED OR UNDER EXTREMES OF TEMPERATURE, AND ARE ABLE TO APPRECIATE THE HAZARDS WHICH MAY BE ASSOCIATED WITH, AND THE PRECAUTIONS TO BE TAKEN WITH, SUCH EQUIPMENT



[www.tempsens.com](http://www.tempsens.com)

**TEMSENS INSTRUMENTS (I) PVT. LTD.**

Tempsens Instruments (I) Pvt. Ltd. U# II  
A-190, Road No.5, M.I.A., Udaipur india

**Ph. :** +91-294-3500629(D), 3500600, **Fax :** +91-294-2500650

**Email :** [tech@tempsens.com](mailto:tech@tempsens.com)